

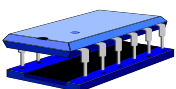

Introduction:

This document is for building the MNS (Microcontrollergesteuerte nostalgische Stationsuhr) scope clock project with all the selected components necessary. You will need to have a relatively high knowledge in the area of high voltage electronics since the device features **lethal high voltage over 1000V**. I do not take any responsibility for future injury or death of anybody building the project or guarantee it's function. Currents of more than 20mA can be deadly! Not only touching may pose danger, at 1000V or more a misguided approach is enough to make a spark accidentally arc from the device to nearest ground which may be yourself. Particularly dangerous are the direct and alternating currents with low frequency, for example the 50Hz frequency ! At high voltage, when measuring and probing, even a separated transformer or ground-fault circuit interrupter will not offer any protection! High voltage is only a jerk away and because it's so unpredictable you have to plan ahead every step in the progress. Handling high voltage has to be considered without a doubt dangerous, so NO guessing or CHANCING! Provide a clean and robust structure when putting the kit together! All components should be clearly separated so that no short circuits can occur. Check all the soldering and mountings for short circuits before connecting anything to the power supply. Use an emergency stop switch for safety! However, don't use it as your regular on/off switch. Always wait for at least 30 seconds before handling the circuit board after disconnecting from the power supply, so capacitors have time to discharge.

For safety reasons you will have to build a housing to mount the clock in when it is finally completed. As an adult you will have to take the full responsibility for the building of the kit, for yourself while building the kit and for the operation of the completed kit !



Elektronik Modules and Kits Owner: Elke Thiem, Jean-Hofmann-Str. 21,
D-63500 Seligenstadt, Tel. +49 6182-290366, E-Mail: info@thiem-work.de,
URL: www.thiem-work.de, USt-Id: DE 812379577

General information about the tube clock:



Cathode ray tubes (CRTs) are ancient relics of electronics technology since they are nowadays usually replaced by LCDs. However, their distinct green glow and the craftsmanship it took to produce them are fascinating. This kit is a unique way to reuse a CRT in a decorative way. The design offers you the possibility to choose from a variety of several different regular 7cm (3") tubes. Some CRTs however, will require adjustments (R50-R58) to the voltage divider for the CRT. Large CRTs with a diameter larger than 7cm can also be used; however most of them do require a separate additional power source.

The clock is designed to decode the signals of the European time signal transmitter DCF77 located close to Frankfurt. Lacking these signals the clock in the radio amateur version uses the (European) power grid frequency of **50Hz** to keep the time as well. Optionally, a 60Hz version is available upon request. The non-radio amateur version with all hourly numbers automatically switches between 50Hz and 60Hz. In case of 60Hz the US format of the date is displayed. For users in the **UK** receiving the DCF77 this version offers the option to switch to CET-1h. The image repetition frequency is also set synchronous the power grid frequency. Therefore scattering fields from neighboring devices won't distort the image, so you won't have to shield the CRT from the magnetic fields.

Operation:

If you decide not to use a DCF77 receiver, two push button switches at CON1 can be used to set time and date.

Note: The version with all hourly numbers does not feature all of the following switching possibilities.

Connection of the switches at CON1: T2 switch between pin 1+2 and T1 switch between pin 1+3

- Pressing T1 once activates the time setting mode
- Within 60 seconds the minute can be set using T2 (either repeated pressing or holding)
- Pressing T1 again switches to hour setting mode
- Within 60 seconds the hour can be set using T2 (either repeated pressing or holding)
- Pressing T1 again switches to day setting mode
- Within 60 seconds the day can be set using T2 (either repeated pressing or holding)
- Pressing T1 again switches to month setting mode
- Within 60 seconds the month can be set using T2 (either repeated pressing or holding)
- Pressing T1 again switches to year setting mode
- Within 60 seconds the year can be set using T2 (either repeated pressing or holding)
- Pressing T1 again leaves the time setting mode

Only 'radio amateur version'

- Pressing T1 twice alternates between date display, digital time display and no additional display
- Pressing T2 alternates between CET and UTC.
Note: When switching from CET to UTC right after midnight and thus after a date leap the displayed date will remain untouched. This is not due to the laziness of the programmer, but to the fact that the microcontroller memory was insufficient for this.
- To manually set the clock to CET daylight savings time, connect pins 3 and 4 on CON2.

Only 'non-amateur radio version', with all hourly numbers

- Pressing T1 twice alternates between date display and non date display
- Pressing T2 alternates between CET and CET – 1h

Adjusting the image position and size

Adjusting the image position and size will be necessary at (first) startup or after changing the CRT. To do so turn the precision trimmers carefully to you get the image in the right position.

R41 X-Position	R31 Y-Position
R10 X-Size	R14 Y-Size

Adjusting the picture brightness and sharpness

If the tube in use is compatible to the values of the resistors R50 to R58, the brightness can be varied from completely dark to very bright using R52. If varying R52 does not suffice, vary R53. The brightness should not be turned so bright that the beam jumps become visible. By alternatingly varying R51 and R50 the sharpness can be adjusted.

R52: brightness
R51: focus
R50: astigmatism

Choosing the anode voltage

This is the negative cathode voltage. By placing the jumper over the connections of JP3 the one can choose between -600V (connect jumper 2+1) or -900V (connect jumper 2+3). Higher voltage causes brighter and sharper pictures, however also an increased wear of the tube. The picture will become smaller with increased voltage because the electron ray is faster and thus harder to divert.

Connecting the power supply

- 12 to 16V AC, 120mA at X2 pin 1+2.
Hint: The power dissipation in the voltage regulators IC5 and IC6 rises with higher entrance AC voltage. If it exceeds approx. 14V AC, an additional heatsink should be mounted.
Note: The metal mounting plate is not grounded!
- 210 to 240V AC, 20mA at X3 pin 1+2.
CAUTION! The PCB should under no circumstances be connected directly to the power grid! This would set the entire kit to the potential of the power grid, which is most obviously lethal!
Hint: A small transformer 230V/12V, 6 to 10VA in reverse operation can be used to generate 230V separately.
- Filament voltage: 6,3V, at X1 pin 1+2, 100mA to 400mA (depending upon the tube used).
Note: Some tubes need only 4V
CAUTION! This voltage must be electrically separated against all other potentials, including ground, with a dielectric strength of *at least* 1000V!

CAUTION! Please never trust the values on a transformer always check under load.

Connection of the CRT

The lines to the deflection plates should be installed causing as little capacitance as possible; i.e. *not* in a cable loom, since additional capacitance causes edge blurring.

If using a CRT with the cathode heating filament electrically connected to the cathode the resistors R61 and R62 have to be removed.

List of CRT types that have already been tested with the kit and the different modifications they require:

Crt type	Modification
DG 7-12 C	none, base such as DG 7-52 A
DG 7-16	none
DG 7-32	Increase R53 value of 20k to 100k
DG 7-52 A	Decrease R53 value of 20k to 39k
7-210 GH	none, NO full screen range usable
7 S 4	Decrease R53 value of 20k to 39k
7 S 401	G4 + G5 + G2 + post acceleration connector
BW-Y-101 (2 AP 1 A)	Increase R53 value of 20k to 100k
D10-160 GH	Increase R55 using an additional 1M resistor
B13S6	Bypass R53 with 3,3k and R48 with 1K. Add 390k to R54 in series. Connect the post acceleration to cathode D15 (+300V suffices, however up to 2000V works better).
5ADP-1	Increase R54 value of 82k to 470k and add a cascade for post acceleration



The CRT is connected with the printed circuit board as follows:

Tube socket D7-16	Tube pin D7-16	Signal	Description	Pin CON3 on the board	Tube pin B7 S2
	1	FIL1	Heating 6.3 VAC	10	14
	2	FIL2	Heating 6.3 VAC	9	1
	3	G1	Jet stream	8	3
	4	K	Cathode	7	2
	5	G3	Focus	6	4
	6	DX2	X-diverson	3	7
	7	DX1	X-diverson	4	8
	8	A	Anode	5	9, 12, a
	9	DY1	Vertical deflection	2	10
	10	DY2	Vertical deflection	1	11

Connection of the DCF77 – receiver

The DCF77 impulses have to be “positive”, i.e. the short pulse has to be “HIGH” and the long pulse “LOW”. The impulses are fed to pin 4 at CON2; ground is put on pin 1. The power supply voltage for the receiver module can either be taken from pin 3 at CON 2 (5V) or pin 2 at CON 2 (12V).

The status of the DCF reception is displayed as follows:

Symbol	Description
	Clock runs power grid synchronized. No DCF reception or no receiver attached.
	DCF impulses detected, however faulty reception or not yet synchronized
	Correct signal received and clock is synchronized

Hints for assembly

Thermally couple the transistor couples T3 - T4 and T5 - T6 with the nuts and bolts provided. Don't forget to apply thermal compound between them.
Ground the casing of the oscillating crystal using e.g. a clamp or soldering a wire to it.

Hint: Always the partslist is valid in case of unclear construction unit value/designations!

Start-up and testing

Before you connect the CRT and insert the ICs into their sockets check the following points.

All values are against ground and with the jumper put JP3 between pins 1 and 2, yielding - 600V anode voltage.

- +5V at Pin20 of IC1
- +12 V at Pin8 of IC3
- -12 V at Pin4 of IC3
- +250V at positive terminal of C26
- approx. -600V at any connection of R61

- Proceed with the ICs and CRT not yet connected:
Connect IC2 pin 1 to IC4 pin 7 and IC2 pin 5 to IC3 pin 7 (simply stick a wire into the respective sockets).
- Put R50 and R52 into a central position and R51 into the left stopping position
- Adjust voltage between pin 1 and pin 2 at CON3 with R31 to approximately 0V.
- Adjust voltage between pin 3 and pin 4 at CON3 with R41 to approximately 0V.

- Turn off the power, connect the CRT, then turn the power back on. You should now be

able to see a dot on the screen. If necessary adjust the central position with R31 and R41.

- Adjust the dot as round as possible with R50, then set it as sharp as possible with R51 (smallest diameter).
- Turn off the power, connect the ICs, then turn the power back on.
- Adjust the picture size with R10 and R14. The picture position might have to be readjusted.

Miscellaneous

When selecting the CRT, pay attention to a fully usable screen. On some CRT the maximum angle of deflection is limited to usually a rectangular cutout.

CAUTION!

If using a CRT with the pins situated directly *in* the glass extreme care has to be taken. The glass may break from the slightest bit of force on the pins! Compared to this a raw egg is made of granite! Fix bent pins using suitable tools in such a way that will avoid any torque or force on the glass! Only put the socket on perfectly straight pins.

Although the image repetition frequency of 50Hz makes the image quite insensitive to equally alternating magnetic fields, strong fields can still become disturbing. So if the hands are no longer matched correctly or diverge from their fulcrum, if the numbers are no longer where they are supposed to be, the only remedy is a bigger distance to the distortion or a turning of the transformer.

A high voltage cascade for the post acceleration

Larger CRT tubes often need an additional post acceleration voltage in the kV-range. The respective connection can usually be found at the side of the glass bulb. For a first shot it can be set to +300V, a voltage found at the cathode of D15. Together with the -900V at the cathode of the tube this yields 1200V, which is usually sufficient for first signs of life.

To achieve a brighter picture, a additional cascade setup can be applied, which may look something like this:

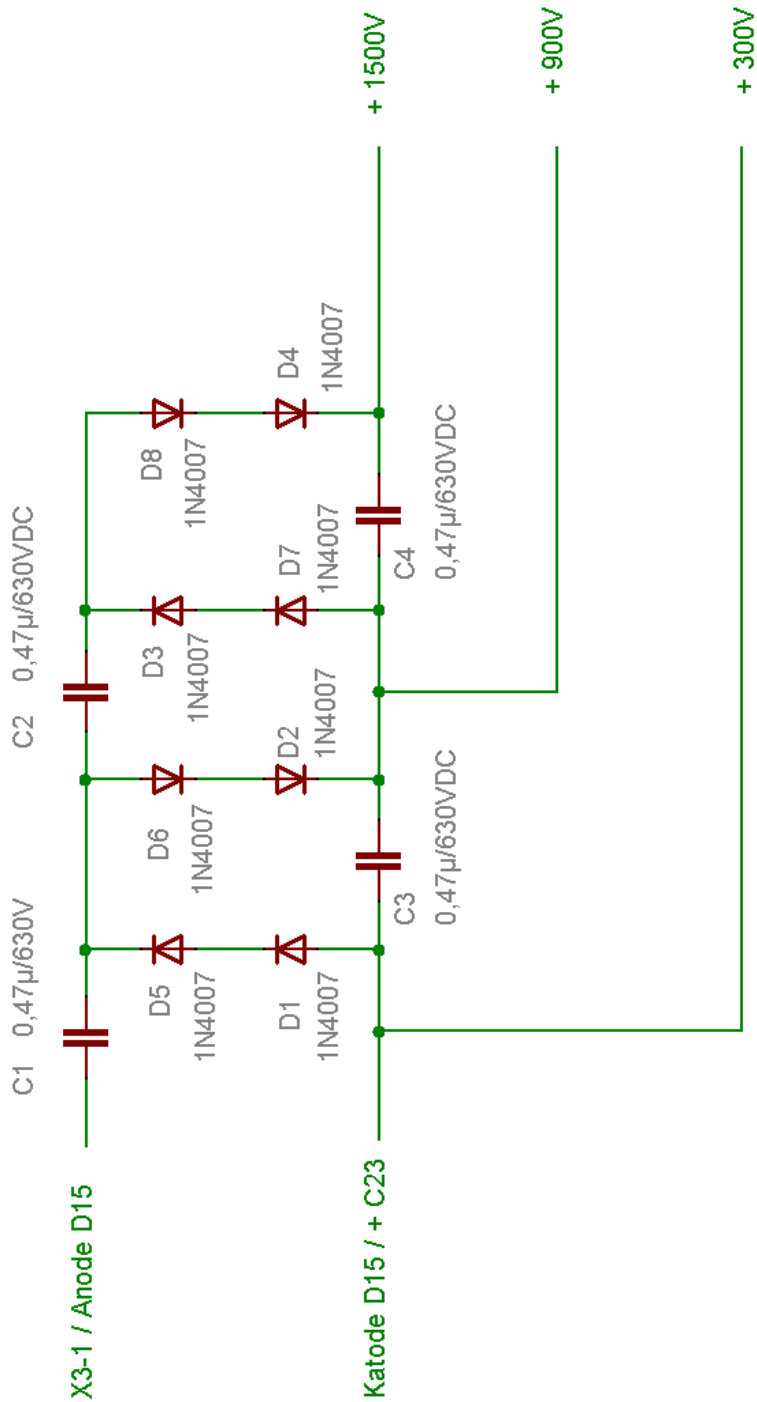

(each with full page in the original documents)

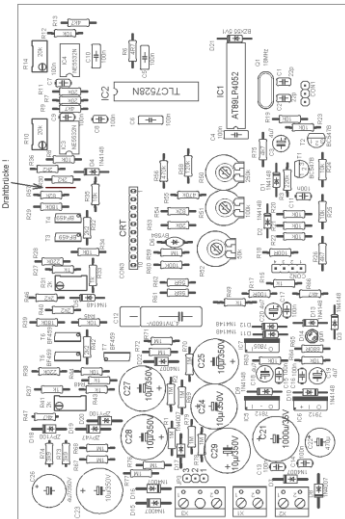
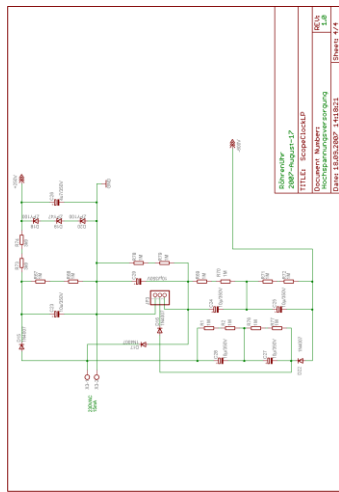
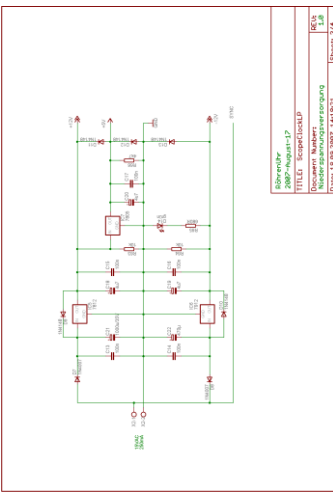
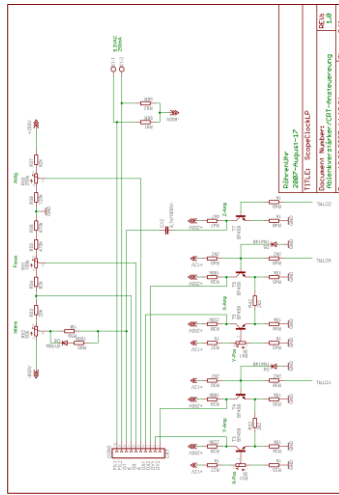
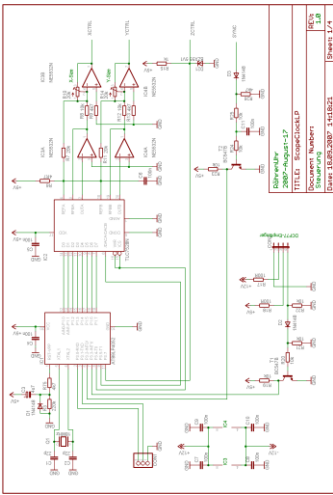

Parts list scope clock next page